



WEB BASED APPLICATION SPECIFIC INSTALLATION INSTRUCTIONS



Replacing Basement Windows

Although all possible measures have been taken to insure the accuracy of the material presented, WIXSYS, and the author are not liable and do not assume any liability in case of misinterpretation of directions, misapplication, improper installation, or typographical error.

Installing Basement Windows

Basement Windows need replacing also and there are special vinyl windows made specifically for replacing old wooden or steel basement windows.

Most old basement windows swing in - either down or up. The vinyl basement window is primarily a hopper window also with the hinge side down and the operating handle and locks on the top of the sash. In some instances, a small slider window can be used, as shown below.

The basic type of vinyl basement window is built exactly like a regular double hung. It has a 3-1/4" frame and 3/4" to 7/8" insulated glass. It will install the same as a replacement window, i.e. against a blindstop. If the old window is a steel type, the instructions for removal and preparation of the opening found in the metal window section will be basically the same for a basement window.

For most wood windows installed directly to the masonry, the old window has to be removed completely. Once the old window is removed, a wood "buck" can be fashioned from 1" x 4" or 1" x 6" pine boards. These boards should be fastened to the masonry opening on all four sides with concrete nails or a power nailer. Be sure to mount them plumb and square in the opening.



Before: Old Wood Basement Window



After: New Hopper Basement Window

A quality silicone sealer can seal where the wood buck meets the masonry. It is advisable to use treated lumber or use a sealer to keep the wood from rotting or deteriorating.

Note: Once the wood buck is in position, you can then calculate the proper window size to purchase. Windows.



New Slider Basement Window

Removing Steel Basement Windows



Old Steel Basement Window

Look at the section in the manual covering installing windows in Masonry. It will give you some information on how the old window is anchored in the block or masonry foundation wall. Using this information you can either remove the old window and fashion the new wood buck as shown here, or you can mount the new window to the left-in-place old frame.



Dryer Vent included in Hopper

Basic Installation

1. As in most replacement situations, blind stops are recommended. This provides a firm surface to mount the window against, and assures weathertightness. Install blindstops of 1/2" x 3/4" stop material or 1/2" quarter-round moulding. Set the stops 1/2" from the outside edge of the installed buck.

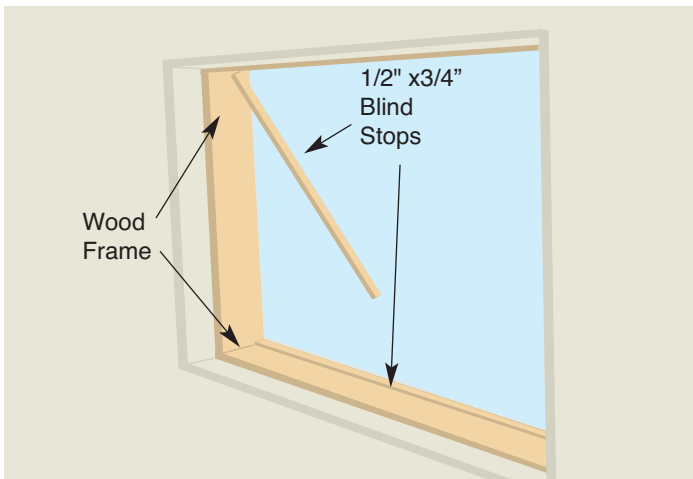

2. Caulk around the inside of the blindstops and lay a bead of caulk approximately in the middle of where the window will rest on the buck.

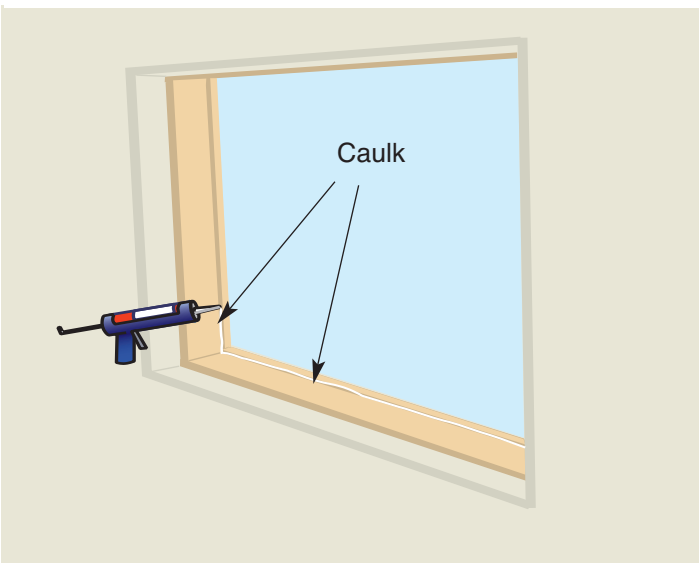

3. Insert the locked window into the opening from inside the house.

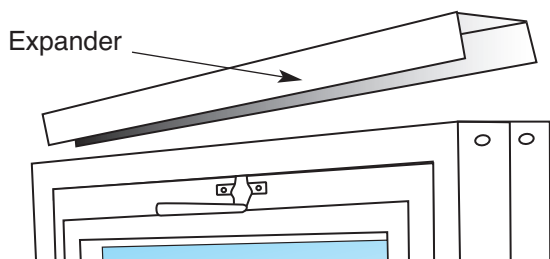

Shim as necessary making sure to shim on both sides behind the installation screw holes. On top, shims must be placed directly over the locks to maintain proper clearance between header and sash to assure proper window operation.

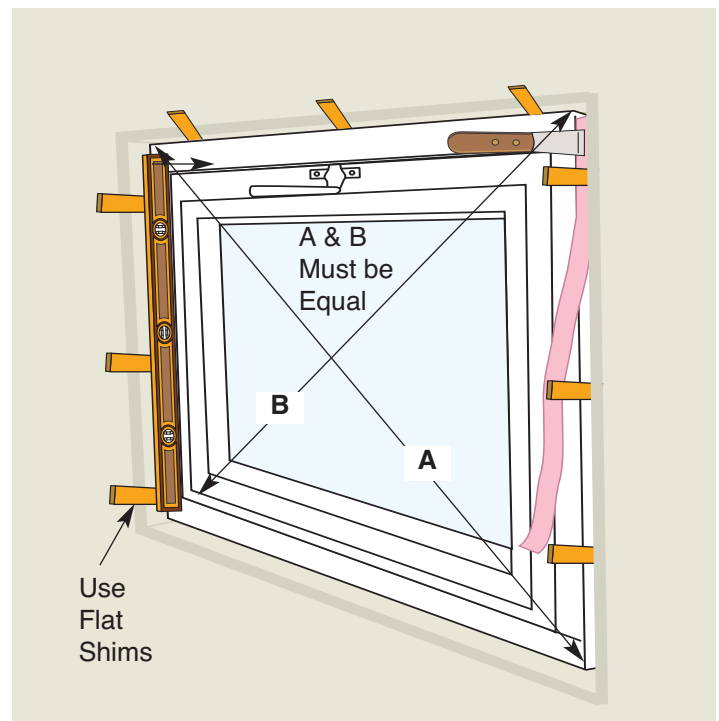

4. Check plumb and square with a level, and measure the diagonals to see if the window is square. Adjust shims if necessary. Place insulation between frame and opening.



5. Using 1/8" drill bit, drill pilot holes through the installation hole into the wood buck. Mount the window with screws provided in the hardware kit.

6. Put finishing trim around the inside of the window and caulk the perimeter. Finish off the wood and moulding with a quality stain or paint.

Installing Vinyl Windows in Masonry

In most masonry applications, the old frame will remain and installation will be as described previously for wood or metal. In those instances where the windows to be replaced were installed in a block opening (block, brick or stone), the opening depth will be 6" to 9" and require a wood frame (wood buck) for installation. Also you must allow an additional 1 1/2" in the width and 3/4" in height when you measure. Order the smaller replacement window size to allow for the use of the wood frame to attach to the masonry opening.

If the old window is a metal window "cemented in," it will need to be "cut out" as you would do with a steel window. The installed wood buck will butt up against the remaining metal frame on the sides and top.

If the old window is wood, it usually can be totally removed.

Once the old window is removed, clean opening and remove old caulk. Using 3/4" plywood or 1" x 6" or 1" x 4" pine, install a wood frame across the top and on both sides using cut nails to anchor wood into the masonry.

If desired, cover the wood buck with coil stock before placing in opening. Also, the exposed outside areas can be covered with wood trim or capping as necessary.

Using Aluminum angle or wood molding (1" x 1") create outside "blindstop" along outside of wood frame leaving enough space (3 1/4") for replacement window.

Install the window against the "blindstop" and trim outside and inside as necessary for completed job.

Pre-extruded shapes or available "Snap-Trim" can make the job easier. Mount the angle of the snap trim with "pop rivet" to the top of window. After placed in opening, mount angle to other sides.

The chief method of installation of new windows in a concrete block wall system is with a tapered wood buck. The windows and doors are of a "flange" design, screwed to the wood buck usually with a sheetrock interior return and a stucco wash finish on the outside. Where the upper stories are allowed to be frame, fin design windows are used.

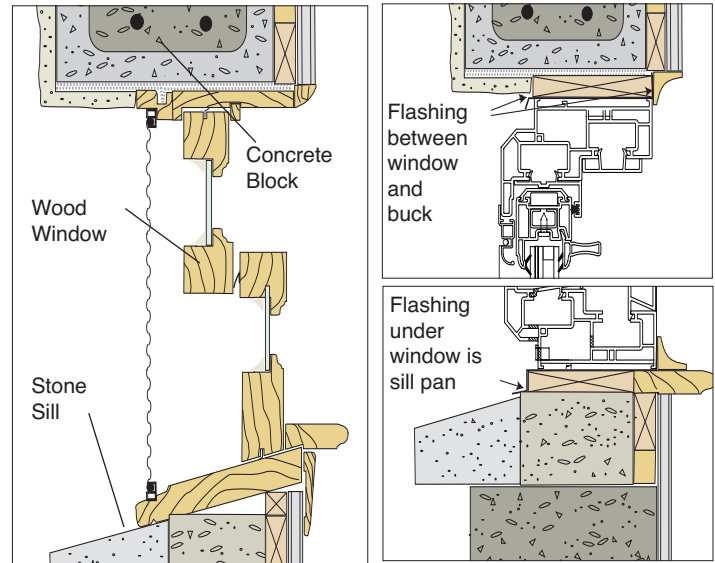

A. Flange

Application: A "flange" allows the unit to be applied against a wood buck fastened to the rough opening. Flange mount is used most often with concrete block, such as CBS construction. The window is mounted with screws applied through the frame, into the buck.

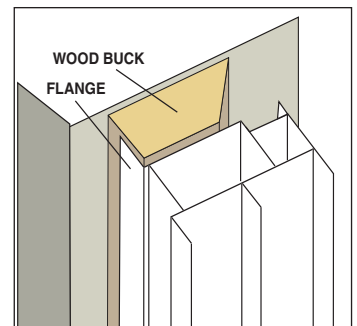

B. Fin Application:

A nailing "fin" on a vinyl window is integrally affixed to the frame between the outer and the interior edge. Fin mounting is used in wood frame construction by nailing through the fin into the wood framing and sheathing.

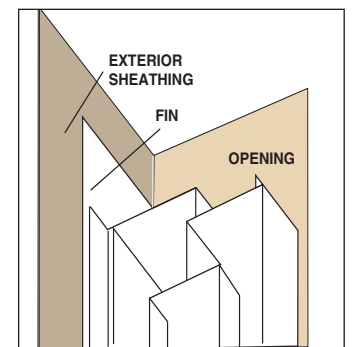

C. Flush Application:

When the unit does not contain a flange or a fin, it can be mounted flush in the opening by using mounting screws through the jambs into the rough opening frame.

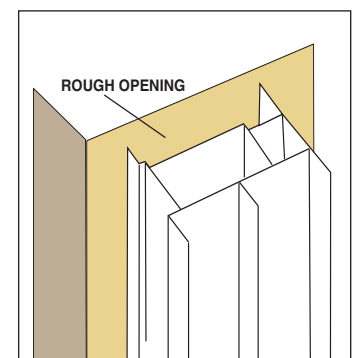

Picking the Proper Sealant

AWDI understands that the application of a sealant is as crucial as the choice of sealant. When a bead of sealant is applied to a joint there are severable factors to consider:

- Adhesion
- Flexibility
- Durability
- Compatibility
- Temp, Weather, Exposure)
- Aesthetics

Within these three performance aspects there are countless combinations of applications, substrates and conditions a sealant is exposed to.

Bedding Joints:

For bedding joints, it is especially important that the sealant meet AAMA 800-802, and is of the right consistency and made up of 100% solids so it will not shrink after cure, unlike solvent and latex based sealants that shrink and create gaps after curing.

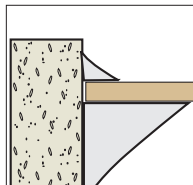

Fillet Joints:

A fillet joint is formed when two surfaces come together to form a right angle. The sealant used to join these two surfaces is triangular in shape. The sealant must adhere to the variety of substrates you're faced with. Without strong adhesion there is a high chance that the sealant will pull away from the substrate allowing for air and water infiltration.

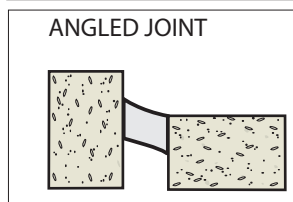
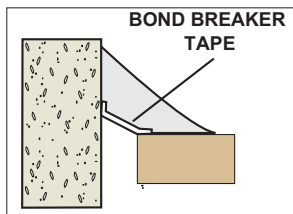

Control Joints:

A control joint is formed when two similar or dissimilar materials meet or when substrates do not form a right angle. This joint will require both a backer rod and sealant for proper application. This joint can be as wide as 5/8 inch and be prone to extreme movement, a highly flexible sealant is necessary for a reliable seal with this application. In order to successfully install a window or door and effect a lasting weathertight seal, AWDI recommends an ASTM C920, Class 50 sealant such as premium

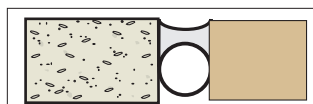
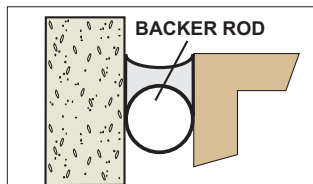

DYNAFLEX® from DAP as a good representative to seal the exterior joints of windows and exterior finish materials. The best choice is a sealant that meets AAMA 800-802 to assure proper adhesion to the most common building materials and that is compatible with WRB and flashing tapes; and can be used in a wide temperature range and wet surfaces.



Desired Properties

- No Shrinkage
- Locks out air and water infiltration to protect integrity of the seal
- Proven Wet Surface Application
- Ability to use the same sealant in warm and cold temperature situations to produce consistent results. 0F – 140F cold and warm weather application
- Strong Adhesion / All Surfaces Will stick to even the most difficult to bond building materials
- 5X stretch, 50% joint movement Long term durability assurance even with expansion and contraction of building materials
- 24 hour fast cure, paintable 1 HR. Fast cure to protect the building structure from outside forces and quick paintability saves time
- Achieves bubbling resistance faster to ensure optimal aesthetics
- 4,600 + Color Matches ensures perfect color match to all primary building materials
- Dirt & Dust Resistance ensures optimal visual appeal long after an installation
- UV Resistance
- Long term durability to compliment the durability of the building structure

Spray Foam Insulation

While the term “Spray Foam” is often widely used in construction, there are two different types and each has its advantages and disadvantage.

Spray foam has been shunned by window installers and manufacturers over the years because foams, in the past, have either continued to expand after trim has been applied deforming the more pliable vinyl window frames, or because they have been over used to fill the gaps left when old windows are removed and the underlying rough opening has been exposed.

Make sure the foam you use has been tested in accordance with AAMA 812 and meets standard for low pressure development.

Most standards applying to window installation do not delineate between open cell foam and closed cell foam, the more popular “minimal expansion” foams are most frequently used and they are mostly closed cell. More confusing yet, is when foams are recommended, the compressed foam tape alternatives are called out to be open cell.

When it comes to Spray Foams, it helps to understand the differences. Open-cell spray foam (ocSPF) has a cell structure where the cells are filled with air. The open-cell structure renders soft, flexible foam, with a density of about 0.5-0.8 pounds per cubic foot (pcf).

The R-value per inch of open-cell foam typically ranges from R3.6 to R4.5 per inch. Unlike fiberglass and cellulose, the fine cell structure of ocSPF makes it air-impermeable at certain thicknesses. The air-impermeability of ocSPF qualifies it as an air-barrier material, dramatically reducing air leakage through the building envelope, significantly lowering the building’s heating and cooling costs. However, ocSPF, like fiberglass and cellulose insulations, is moisture-permeable, and may require the installation of a vapor retarder in colder climates.

Closed-cell spray foam (ccSPF) has a closed cell structure which yields rigid hard foam, with a



density of 1.8-2.3 pound per cubic foot (pcf), and can provide structural enhancement in certain framed buildings. The smaller cells trap insulating gas from the curing, which has a lower thermal conductivity than still air, and increases the R-value to anywhere from R5.8 to R6.9 per inch.

Like ocSPF, ccSPF is also air impermeable at certain thicknesses and can qualify as an air-barrier material. The bigger benefit is that the closed-cell structure of ccSPF also makes it water-resistant, and is the only spray foam that can be used where contact with water is likely.

At a thickness of 1.5 inches, no additional vapor retarder is required for most applications.

Desired Properties

- Make sure the foam used has been tested in accordance with AAMA 812 and meets standard for low pressure development.
- Quick Setting Formulation: can be cut or trimmed in less than 1 hour
- Cold Temperature Application: can be applied in temperatures as low as 14F
- Insulation Value of R5: makes it an efficient method for stopping air and moisture infiltration
- Remains Flexible Once Cured: will not crack or dry out

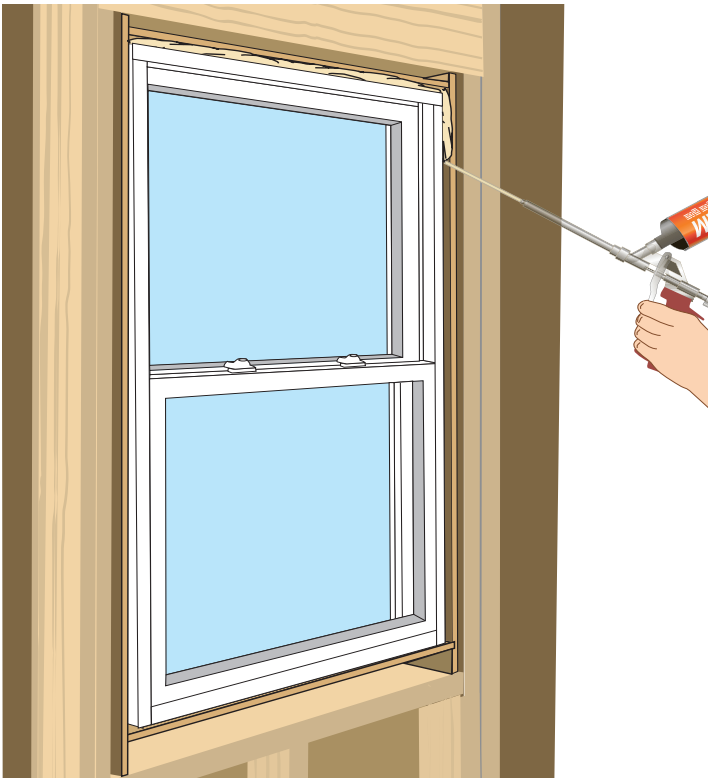

Important tips:

- Similar to the sealant gun, it is critical that you balance the movement of the foam gun or straw barrel and how you dispense the foam so that the foam makes contact with both the rough or existing window frame and replacement window frame.
- If the dispensed foam does not make contact with both the rough frame and the window frame, there won't be an adequate bond to seal out water and air.
- Industry Standards suggest application of 1 inch beads, separated by an equal space. Be careful not to create two vapor barriers - one at the exterior and one at the interior. Make sure there is the ability for the opening to breathe to the cold side for drying and drainage. Use backer rod about one inch in the sill as a stop to make a workable back dam
- When applying foam around the perimeter of the window or door, you must maintain a minimum depth of 1 inch. This depth is required to provide the correct thermal performance, to help improve energy savings, and to protect against condensation problems.
- When applying foam as a back dam to the gap between the window frame and the rough sill, do not allow the foam to extend to the exterior edge of the opening. Maintain a minimum of a 1 inch gap between the foam and the exterior edge of the rough sill. If foam fills this gap at the sill, any water from leakage will not be able to drain to the drainage plane or exterior cladding surface. Place backer rod the length of the sill, 1" from edge and use it as a back dam guide.

Using Spray Foam

For the best installation, it is necessary for the gap around the window or door to be sealed to block out air, water and vapor penetration. ccSPF can do that well if selected and used properly. Improper use can create water traps, impede drainage and exert excessive pressure to the window frame during expansion.

Remember: Vapor barriers need to be applied on the warm side of the opening. Double vapor barriers (one on the warm side and another on the cool side) encourage condensation between and will trap the resulting condensation. Also, window installation cavities (the space between the window frame and the rough opening, or left-in-place old window frame) need to "breathe" to the outside, and allow drainage of collected water to the outside.

Used wisely, ccSPF can be the best solution. AWDI recommends DAP® DRAFTSTOP 812 Window and Door foam. DAP® DRAFTSTOP 812 also achieves a thermal performance of R-5 per inch.

Application

DAP DRAFTSTOP Foam is applied using a Foam Applicator Gun. This foam and gun combination allows for more precise application than the straw grade foam alternative. This gun offers a rear valve used to control the size of bead applied into the openings. The valve also allows the life of the foam to be extended by closing the opening of the barrel for future use.

For even smaller openings, a detachable screw on top is included with the gun to be able to fill gaps as small as ¼" wide.

